

# ***DV15***

USER'S MANUAL



## INDEX

OVIS .....	1	COMB and BUTT PLATE ADJUSTMENT .....	12
WARNING AND SAFETY .....	2	REMOVING BOLT .....	13
USER INSTRUCTIONS .....	4	CLEANING AND MAINTENANCE INSTRUCTIONS .....	14
TECHNICAL SPECIFICATIONS .....	5	BOLT MAINTENANCE .....	15
BOLT SAFETY .....	6	CLEANING AND MAINTENANCE KIT .....	16
TRIGGER SAFETY .....	7	PARTS CHART .....	18
MAGAZINE LOADING .....	8	STOCK SET .....	19
AMMO LOADING .....	9	RECEIVER .....	20
AMMO UNLOADING .....	10	BOLT .....	21
TRIGGER ADJUSTMENT .....	11	FIRING PIN .....	22
		SAFETY SYSTEM AND MAGAZINE .....	23
		TRIGGER GROUP .....	24
		CERTIFICATE OF GUARANTEE .....	25



**OVIS**

*Our first bolt action rifle 'Ovis', which takes its name from “**Ovis Gmelinii Anatolica**” -the Anatolian wild sheep- , which has been for thousands of years in our lands, is a combination of cutting- edge technologies and excellent components. For many people, it is enough, a rifle can be light or shoot at a longer distance. However, when designing Ovis, we took care that it also addressed your senses.*

*Ovis is an aluminum tactical rifle and has two different wooden versions. Ovis, which is integrated with 308 win caliber forged barrel, is produced with rigorous engineering of Huğlu to be resistant to steep and tough conditions just like Anatolian wild sheep.*

*We know that as the years go by, things that leave us scarred are reduced. If you want to add a trail to your life you will not forget, we invite you to meet our masterpiece Ovis.*



## **WARNING AND SAFETY**

**BEFORE USING YOUR GUN, PLEASE READ  
CAREFULLY USER'S MANUAL**

**IMPORTANT WARNING:**

**BEFORE DISASSEMBLING GUN**

- 1) POINT THE GUN TO A SAFETY PLACE.**
- 2) MAKE SURE THAT EMPTY MAGAZINE.**
- 3) BE SURE THAT CHAMBER IS EMPTY.**

Dear User,

-We thank you very much choosing our fine art products.

-Please understand the mean that the first step of safety is yourself. Do not forget ever firearms are different however much you are experienced.

- The rifle is not used in accordance with the safety instructions and user's manual; injuries that may result in material accidents and death may occur. Our company is not responsible for the damages that will occur.

-Our company is not responsible for the use of non-standard or damaged ammunition in your rifle.

-The last checks of your rifle were made by our company and carefully packed.

-Our company is not responsible for any problems that occur during the transportation after the purchase. Therefore, carefully inspect the rifle when receiving it.

- These user's manual must always be kept with the rifle.

## WARNING AND SAFETY

- Always treat your rifle like it's loaded.
- Never aim your rifle where you do not intend to shoot.
- Make sure that there is no cartridge in the chamber before putting your rifle down or handing it over to someone else.
- When storing your rifle, always keep the mechanism separate and do not keep cartridge in the chamber.
- Use your rifle only for shooting.
- Never leave a loaded rifle unattended.
- Make sure that the barrel bore, the chamber and the mechanism are clean before loading cartridge into the chamber.
- Always use clean, dry, original, high-quality ammunition manufactured to the appropriate standards for your rifle.
- Never use your rifle when you are drunk, had drugs, when riding, when driving and when you feel yourself unwell.
- While shooting use protection material for your eyes and ears.
- Always keep the safety activated when there is cartridge in the chamber.
- Do not shoot at hard surfaces very close and with a shallow angle because of skipping possibility.
- Always keep your rifle and cartridges away from the children that they cannot reach. If possible, keep in a locked safe place.
- Always make sure that the ejection part is clean.
- Do not put your hand inside the trigger guard until the target is in front of you.
- Before firing, make sure the area where your target is located is secure. The bullet can pierce the target.
- Never fire your firearm near an animal unless it is trained to accept the noise.
- Don't joke with your rifle loaded.
- Always make sure your rifle is empty before cleaning, storing or traveling.
- The rifle does not fire: After the trigger is pulled, if the cartridge does not explode, the barrel of the rifle is turned to a safe area, waiting for 30 seconds due to the possibility of firing in the capsule. If the cartridge does not explode, the bolt is slowly opened and the cartridge is removed from the chamber and destroyed safely. Check the firing pin mark on the cartridge's primer. If firing pin mark is weak or not present, the rifle is sent to the authorized service.
- Do not modify any part of your rifle. Our company is not responsible for serious injuries due to the changes made.
- We hope to be respectful to the nature and environment when using our products.

**AMMUNITION**

Use only factory-manufactured standard ammunition of appropriate caliber, which are in compliance with CIP regulations (International Proof Commission for Firearms and Ammunition) or SAAMI (Sporting Arms and Ammunition Manufacturers' Institute Inc. of the United States). The use of other cartridges could damage the firearm or cause malfunctions or injury to the shooter.

**MAGAZINE REMOVAL**

Using one finger press the magazine catch in the direction to the receiver, and with the remaining fingers grip the magazine bottom, and remove the magazine from the rifle.

**BOLT REMOVAL**

The bolt is moved to the discharge position. By pressing the bolt stop button located on the left side of the body, the bolt is pulled back slowly and the bolt is separated from the rifle.

**BARREL EXERCISE**

The barrel exercise is done in order to prevent the copper contamination of the barrel and extend the life of the barrel. The copper contamination typically occurs as the large and small copper pieces' adhesion to the barrel in the form of

patches and lumps after the shooting. The inside of the bullet which has turned into rough surface as a result of this causes tears in the tail section of the bullet's coating while the bullet is passing through. This prevents the bullet fly properly by increasing the turbulence at the bottom of the bullet. To exercise the barrel of a gun, firstly a good barrel cleaning solution and a good copper solvent are needed.

- Thoroughly clean your gun before firing. Thoroughly dry the barrel. Make a shot.
- Thoroughly clean your barrel with a barrel cleaning solution and dry it (carbon cleaning).
- Then, rub copper cleaning solution on the dry barrel and wait for a while (as much as it is written on its application, about 15-30 minutes) and clean. The cloth will come out in gray blue/green tones. Continue the procedure until the cloth comes out in normal color (if required, re-apply the copper removal solution).
- Then dry the barrel thoroughly and make another shot and repeat the above procedure.
- Repeat this procedure by making 10 shots in total.
- Then, repeat the same procedure in every three shots for 11-30 shots.

- Then, repeat the same procedure in every five shots for 31-50 shots.
- Then, repeat the same procedure in every ten shots for 51-100 shots.
- As a result of these procedures, the barrel becomes flat and smooth. The microscopic pores within the structure of steel, are filled with copper and prevent the accumulation of the copper in the barrel.
- Then, repeat these procedures in every twenty shots in order to make accuracy regular.

The barrel attuned like this becomes to make hundred shots in the same accuracy.

**WARNING!**

During removal of the bolt, the right hand is held in such a way that it grasps the cocking handle and the bolt. It is prevented from damaging the stock.

In order to separate the bolt from the rifle, the cheek on the butt stock should be in the lowest position.

# **OVIS**

## **BOLT ACTION**



<b>CALIBER:</b>	.308 Win
<b>ACCURACY:</b>	3/8 inch in 100 Yards With .308 Win (5 Shots Group Guarantee With Recommended Factory Match Ammunition)
<b>TWIST RATE:</b>	1:12 inch
<b>BARREL:</b>	4 Grooves
<b>MAGAZINE CAPACITY:</b>	3+1
<b>BARREL LENGTH:</b>	26" / 66 cm.
<b>MAX RANGE:</b>	1200 m.
<b>TRIGGER:</b>	Adjustable Trigger Length (0-10 mm), Trigger Weight (800-2000 gr) & Trigger Retaining (0-2 mm.)
<b>STOCK:</b>	Turkish Walnut / Laminated
<b>TOTAL LENGTH:</b>	51" / 130 cm
<b>WEIGHT:</b>	4700 ± 100 gr. (Without Ammo)

**SPECIFICATIONS**

**TECHNICAL  
SPECIFICATIONS**



**45°**

**Bolt Open Position  
(Rifle loading or unloading  
position)**



**30°**

**Bolt Safety Position  
(1st stage open bolt view)**



**0°**

**Bolt Closed Position  
(Ready to fire position)**



**Safety Off  
(Shooting Position)**

◀ **The safety latch is pushed forward to make the rifle ready for firing.**



**Safety On  
(Safe Position)**

◀ **The safety latch is retracted and the rifle is moved to the safe position.**



The cartridge is pressed from the top as shown in the pictures and pushed forward.



The cartridge must be loaded correctly into the magazine as shown in the illustration.



After loading the cartridges into the magazine, pull the bolt back and insert the magazine into its slot.



Once the magazine is assembled, the bolt handle is moved to the forward push position.



The bolt is pushed forward so that the cartridge can be driven into the chamber.



After the cartridge is loaded into the chamber, the bolt handle is locked down and the rifle is ready to fire.



After firing, the above steps are repeated by lifting the bolt handle to reload the cartridge.



When the shot is abandoned while the rifle is loaded with cartridges loaded rifle is turned into a safe area.



The trigger safety is activated by pulling back.



The magazine is removed by pressing the buttons.



The bolt handle is pulled back and the cartridge is unloaded.



### Trigger Pull Weight Adjustment

Turn the screw on the front of the trigger with the hexwrench in the case. Increase the trigger weight by turning it clockwise, decrease the trigger weight by turning it counterclockwise.

**NOTE:** The trigger weight is set by factory to 15N (1.5 kg). Do not turn the screw more than 4 round. Our company is not responsible for any damages caused by trigger which is under standard trigger weight.

### Length of Pull Adjustment

By loosening the screw on the trigger as shown in the figure on the right, you can adjust the distance of the trigger back and forth according to your finger length.





The comb of the stock comes as standard in the picture.



Loosen the screws on the right side of the stock to adjust the comb.



Loosen the screws on the right side of the stock to adjust the butt plate.



Check the height adjustment by placing your rifle on firing position.  
**NOTE:** The comb must be in down position when the bolt is to be disassembled.



**Secure the rifle and turn it into a safe area. Then press the bolt stop button located on the left side of the rifle.**

**Lift the bolt handle and pull it back. Hold down the bolt stop button while doing this. The bolt is removed slowly and carefully so that the extractor do not damage the stock.**



## CLEANING AND MAINTENANCE INSTRUCTIONS

### BEFORE CLEANING AND MAINTAINING YOUR RIFLE;

- Aim the rifle in a safe area and place it in the safety position.
- Remove the magazine and make sure that the chamber is empty.
- Remove the bolt by pressing the bolt stop.
- Do not interfere with your rifle except as instructed in the user's manual.
- For longer and safer use of your rifle, make sure to clean and maintain after the following conditions.
  - \* After each use
  - \* If your rifle gets wet
  - \* After each shot as much as possible
  - \* At least once a year in temperate climates
  - \* At least once a month in tropical or other harsh climates

## INSTRUCTIONS OF PRESERVATION

- The barrel, chamber and other parts suitable for cleaning should be left clean and dry.
- The rifle is ruptured with a rag or spray soaked with suitable gun oil. Excess oil is removed.
- The barrel must be degreased before shooting.
- At very low temperatures, general parts of the rifle should be free from thick oil and a lubricant suitable for this environment should be used.
- Thick protective materials such as grease; it should only be used in long-term storage and in variable climatic conditions, these materials must be completely free of rifle parts.

### DISPOSAL WASTES AFTER CLEANING

- The products used for cleaning should be kept in a way that there is no harmful effect on human and environment and other products like metal, plastic, wood etc. should be separated properly.

## CLEANING OF BARREL INSIDE AND CHAMBER

- If the rifle has not yet been fired or several rounds have been fired, the inside of the barrel and the cartridge chamber must be cleaned with the ramrod by repeating until no powder residue remains.
- When the inside of the barrel is very dirty, it is cleaned with a bronze brush and cleaning solution.
- If the inside of the barrel is not cleaned, the cleaning solution is squeezed into the barrel. Wait around 10 minutes (time may vary according to the solution model), repeat the cleaning with a bronze brush.
- The above operations should be carried out from the chamber to the barrel end. The ramrod must not be moved back and forth in the barrel.
- Clean the barrel and the chamber with a clean cloth and ramrod until only oil stains remain on the cloth.



### DIVISION OF THE BOLT TO THE INTERNAL PARTS

- As shown in the picture on the side, the bolt is removed by loosening the allen screw in the holder.
- The disassembly sequence is loosening the screw, turning the firing pin to the removal stage of the hammer pin, removing the firing pin holder, removing the cocking handle, and removing the firing pin system. Reassembling is the opposite of these operations respectively.

### BOLT CLEANING

- Once the bolt is disassembled as shown in the picture below, firstly the waste oils on the firing pin group and the bullet-shell particles caused by the firing are carefully cleaned.
- The bolt is first cleaned with the steel wire cleaning brush in the cleaning kit and then with the plastic brush the bullet-shell residues are removed from the bolt forehead. Particularly, around the ejecting mechanism must be free of residues.
- The surface of the bolt is cleaned and lubricated by lubricating a clean cloth.

### NOTE:

- While making breech bolt cleaning after each shooting, cocking handle core fixing screw must be tighten.
- Our company is not responsible for the problems because of unauthorised use on firing pin distance adjustment screw.



## 1. Carrying Case

All of the materials required for gun cleaning and described below are placed in the cleaning kit case.

## 2. Ramrod

Ramrod consists of handle and 5 pieces. The parts are screwed together to bring the length of the ramrod to the desired length. It is possible to clean the rifle by connecting bronze brush, cotton brush, plastic brush and cleaning brushes to fasten at ramrod. Furthermore, inside of the barrel is cleaned by screwing the warhead on the end of ramrod and attaching the swab on the warhead.

### **3. Plastic Brush**

It is used by screwing to the end of the segmented ramrod or ramrod wire. It is used for the monitoring of gunpowder residue, gunpowder ash, carbon and metal dirt formed in the barrel after firing.

### **4. Cotton Brush**

It is used by screwing to the end of the segmented ramrod or ramrod wire. It is used for drying the barrel inside.

### **5. Bronze Brush**

It is used by screwing to the end of the segmented ramrod or ramrod wire. It is used for the monitoring of gunpowder residue, gunpowder ash, carbon and metal dirt formed in the barrel after firing.

### **6. Wire Ramrod**

Bronze brush, cotton brush and plastic brush can be screwed to both ends of the wire and the inside of the barrel can be cleaned. In addition, inside of the barrel is cleaned the barrel wire, the warhead ramrod screwed then by installing the cloth.

### **7. Fine Cleaning Brush (Steel Wire)**

It is used by screwing to the end of the segmented ramrod or ramrod wire. It is used for the monitoring of gunpowder residue, gunpowder ash, carbon and metal dirt formed in the barrel after firing.

### **8. Thick Cleaning Brush (Steel Wire)**

It is used by screwing to the end of the segmented ramrod or ramrod wire. It is used for the monitoring of gunpowder

residue, gunpowder ash, carbon and metal dirt formed in the barrel after firing.

### **9. Thick Cleaning Brush (Plastic)**

It is used by screwing to the end of the segmented ramrod or ramrod wire. It is used for the monitoring of gunpowder residue, gunpowder ash, carbon and metal dirt formed in the barrel after firing.

### **10. Fine Cleaning Brush (Plastic)**

It is used by screwing to the end of the segmented ramrod or ramrod wire. It is used for the monitoring of gunpowder residue, gunpowder ash, carbon and metal dirt formed in the barrel after firing.

### **11. Oiler Tube**

There is rifle maintenance oil in the oiler tube and it is used to lubricate the rifle after cleaning.

***OVIS***  
**PARTS CHART**

## Parts List

1. Stock
2. Butt Plate
3. Monopod
4. Monopod Mount Rail
5. Bipod Mount Rail
6. Bipod
7. Top Rail Mount

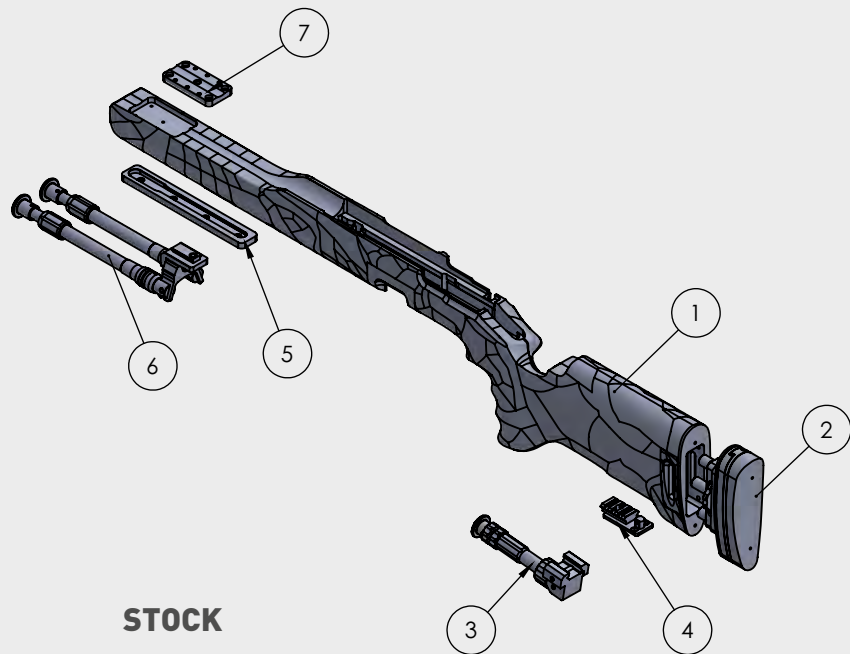

## Part List

1. Barrel
2. Bolt Stop
3. Bolt Stop Pin
4. Frame
5. Bolt Stop Spring
6. Rear Distance Adjustment Ferrule
7. Front Distance Adjustment Ferrule
8. Trigger Guard
9. Front Connection Screw
10. Rear Connection Screw
11. Main Connection Pin

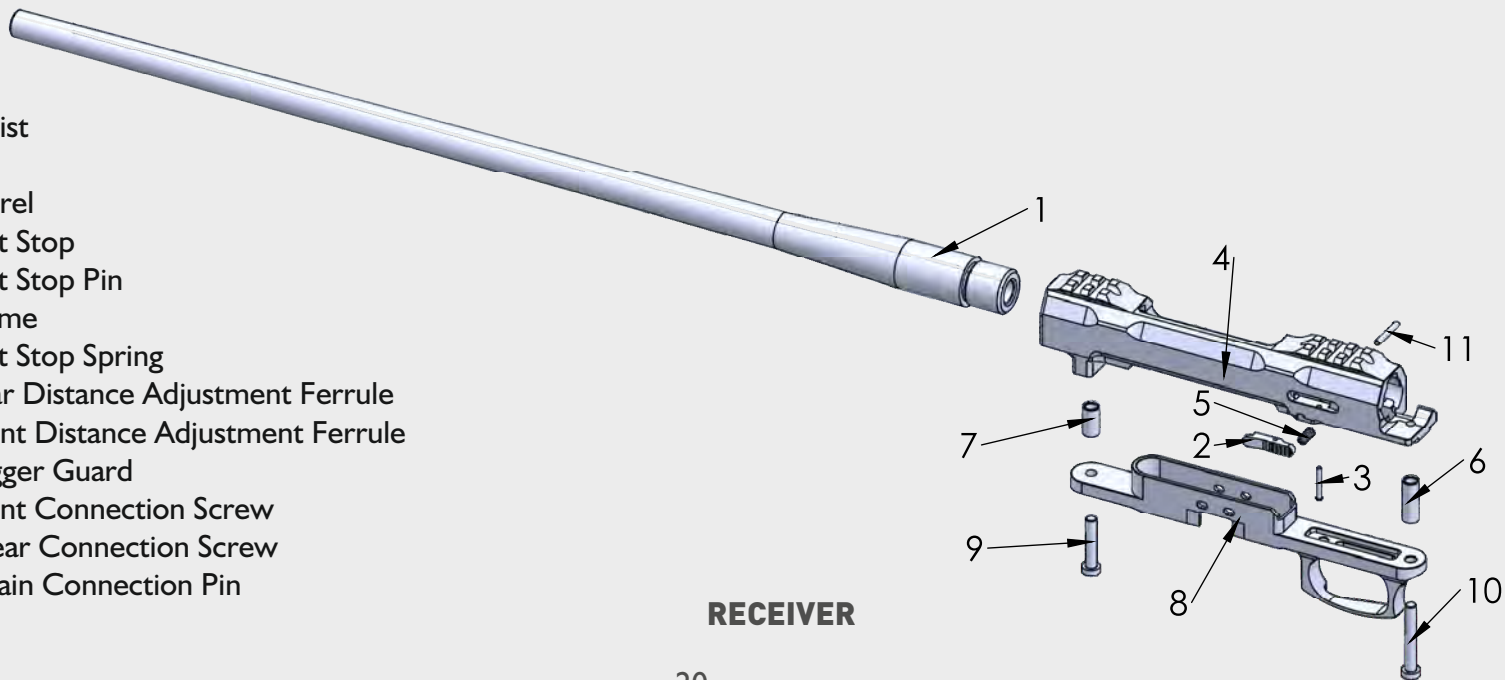

**RECEIVER**

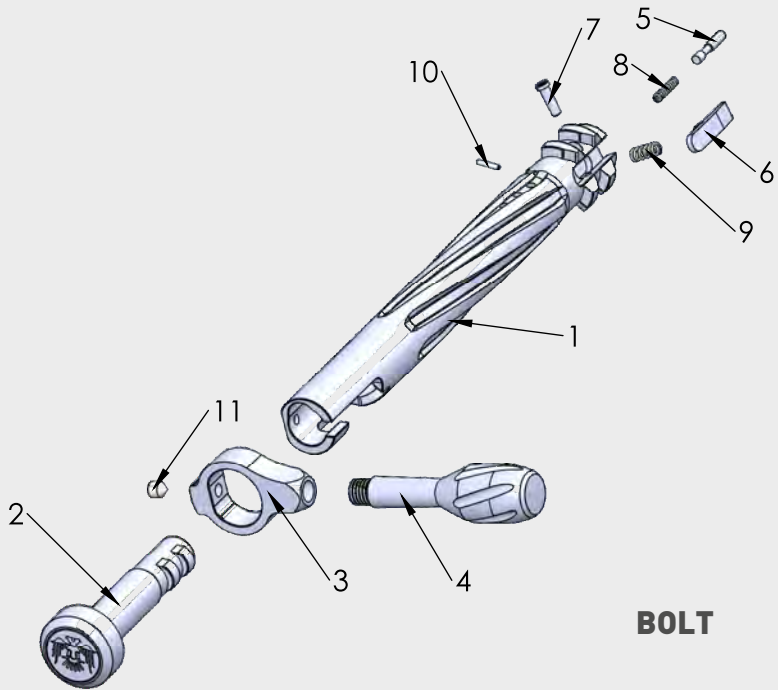

**BOLT**

Parts List

1. Bolt Frame
2. Firing Pin Holder
3. Cocking Handle Core
4. Cocking Handle
5. Ejection Part
6. Extractor
7. Extractor Swing
8. Ejection Part Spring
9. Extractor Spring
10. Ejection Part Pin
11. Cocking Handle Core Fixing Screw

## Parts List

1. Firing Pin
2. Firing Pin Adjustment Shim
3. Hammer
4. Firing Pin Spring
5. Firing Pin Distance Adjustment Screw

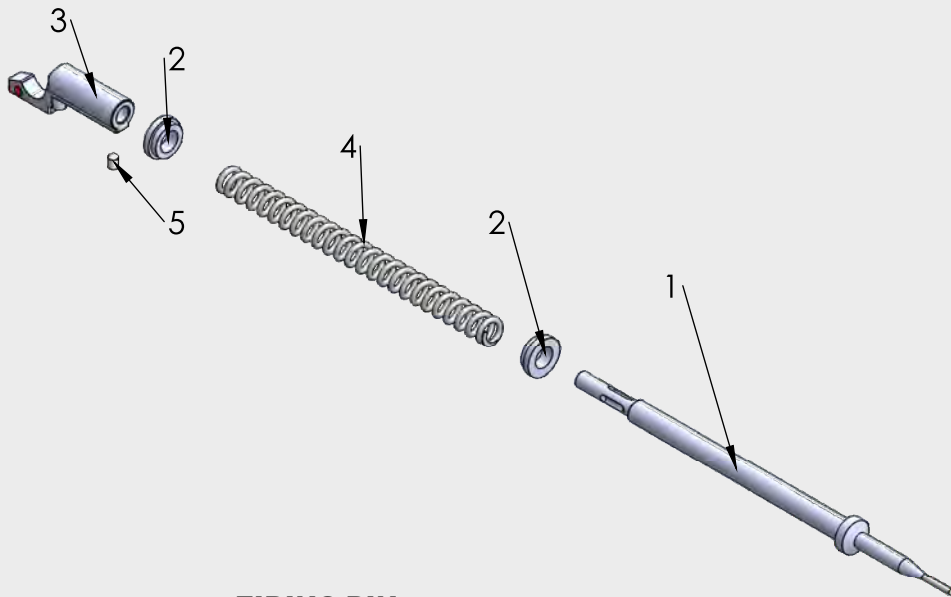

**FIRING PIN**

## Parts List

1. Magazine Lower Cap
2. Magazine Lower Cap Locking Block
3. Magazine Follower
4. Magazine Receiver
5. Magazine Release Latch
6. Magazine Spring
7. Magazine Release Latch Screw
8. Safety System Receiver
9. Safety System Left Lever
10. Safety System Right Lever
11. Safety System Button
12. Safety System Plate
13. Safety System Connection Pin
14. Safety System Lever Fixing Screw
15. Safety System Spring
16. Safety System Pin Retaining Ring

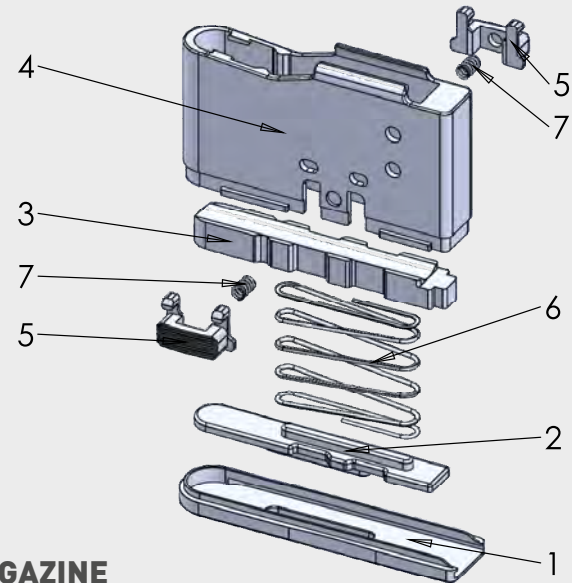
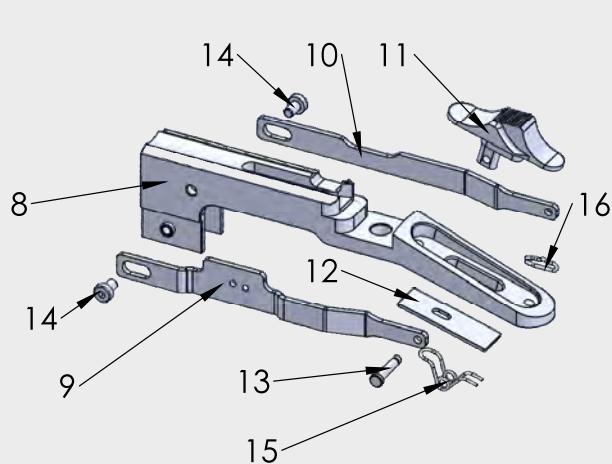

## SAFETY SYSTEM AND MAGAZINE

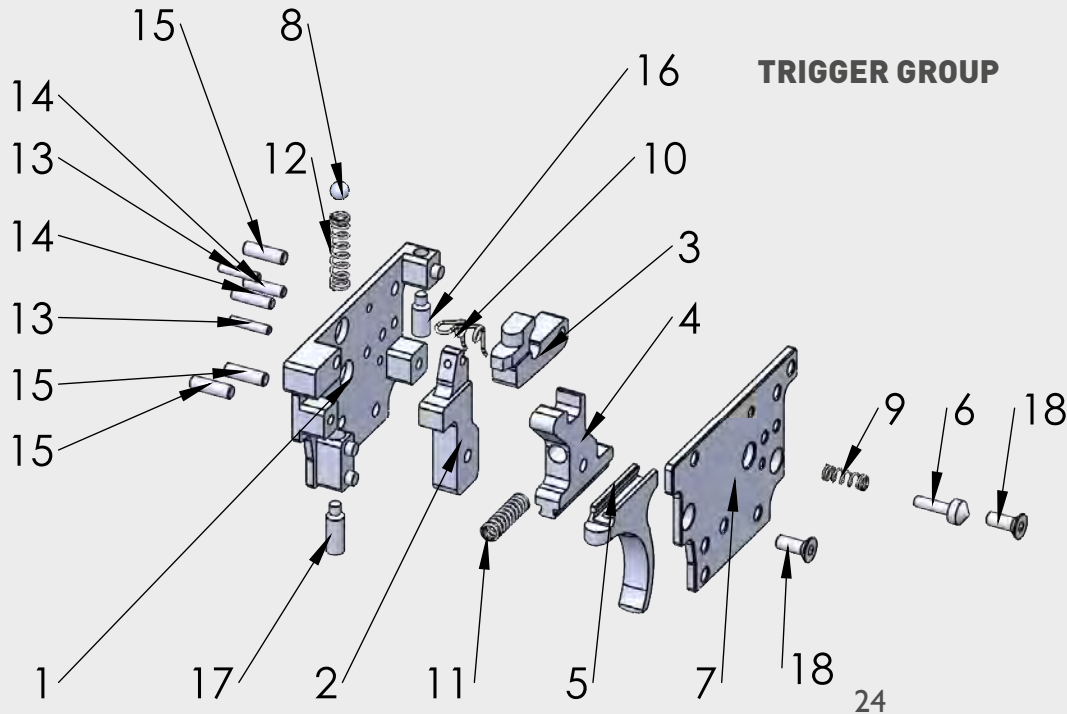

## TRIGGER GROUP

### Parts List

1. Trigger Group Receiver
2. Accelerator
3. Hammer Holder
4. Sear
5. Trigger
6. Trigger Safety Pin
7. Trigger Group Receiver Cover
8. Trigger Weight Adjustment Ball
9. Trigger Safety Spring
10. Hammer Holder Spring
11. Sear Spring
12. Trigger Weight Spring
13. Distance Adjustment Pin
14. Hammer Holder Spring Pin
15. Internal Parts Connection Pin
16. Tensioning Screw
17. Trigger Weight Adjustment Pin
18. Trigger Group Connection Screw

1. Warranty period of our products is one (2) year and starts at the delivery date of the product.

2. In case the delivered product specifications do not conform to the specifications at the time of ordering, objection and claim period for correct product is ten (10) days starting from the date of delivery. In case no objection and claim are made in such period, it shall be deemed that the delivered product is accepted. In case the objection is accepted, the product must be returned to our organization within ten (10) days starting from the date of delivery. The product requested by the customer at the time of ordering will be shipped to the customer provided that our experts issue a report as a result of inspection indicating that the product is unused and there are no faults or defects caused by the customer. Replaced product will be shipped to the customer within three (3) months maximum starting from the date that incorrect product is received by our organization.

3. Technical specifications of the product is listed in the "Technical Specifications" section of this manual.

4. Objections and claims will not be processed and no action will be taken regarding the product if a copy of the invoice is not submitted with the defective-faulty product.

5. Our products will be shipped with an empty chamber using the cargo, mail and shipping method requested by the customer in the event of defects and faults. Our organization shall not be responsible for faults and defects occurred during transport.

6. Our products including all parts are completely under the warranty of our company. Faults and defects occurring as a result of storage, maintenance, and improper use violating the matters specified in the

manual are not covered by the warranty.

7. The period elapsed during repair will be added to the warranty period in case the product failures during the warranty period. Time to repair is 20 business days. Such period shall start on the date that the relevant fault is accepted by the service station. The consumer shall not report the failure via phone, fax, email, registered and reply-paid letter or similar methods. The report to be issued by our aftersales service and quality control experts shall be conclusive evidence as to whether the failures and defects occurring in our products will be covered by the Warranty or not.

8. Time to repair and maintain the product with expired warranty shall be evaluated and notified to the user by our expert personnel in case such product fails or requires maintenance.

9. In case the product fails during the warranty period as a result of either materials and labor or assembly failures, such product will be repaired by our Organization without requesting any labor costs, replaced spare part fees, or other fees.

10. The consumer shall be entitled to request free replacement, refund or discount at the rate of defect in case the product

- Fails minimum four times within one year or more than six times during the warranty period determined by the manufacturer starting from the date of delivery to the consumer provided that such determined warranty period is not expired, and moreover, such failures continually prevent the consumer from utilizing the product,
- Maximum period for repair in 20 business days is exceeded, or
- The report issued by the company's service station determines that the failure specified in the report cannot be repaired despite the

fact that the consumer has exercised the right to repair.

11. Failures arising from improper use of the product violating the matters specified in the manual or serviced by a service location other than the authorized service will not be covered by the warranty.

12. Warnings related to the situations during the use of our products which may be dangerous or harmful to the environment and human health are covered by this manual.

13. The consumer may apply to the Consumer Arbitration Committee or Consumer Court located in the residential area or the consumer's location for the disputes which may arise in relation to the exercise of the rights arising from the warranty.

14. The consumer may apply to the Directorate General of Consumer Protection and Market Surveillance of the Ministry of Customs and Trade in case the Seller fails to give this warranty certificate.

Model:

Cal.:

Barrel Length:

Serial Number:

### **Huđlu Av Tüfekleri Kooperatifi**

Huđlu Mah. Özgürlük Cad.  
No: 40/A 42710  
Beyşehir/Konya/Turkey

Satış Ofisi / Sales Office  
**T.** +90 332 516 16 00  
**F.** +90 332 516 10 31

Fabrika / Factory  
**T.** +90 332 516 11 53 (PBX)  
**F.** +90 332 516 10 32

   [huglu.com.tr](http://huglu.com.tr)